

# Model 75-75-75S

## Triple Reduction Planetary Gear Reducer

### Flange Mount

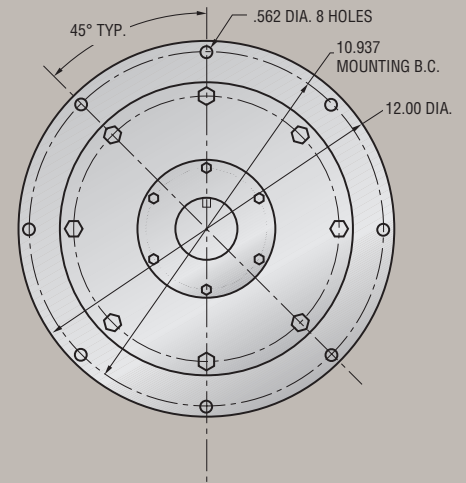
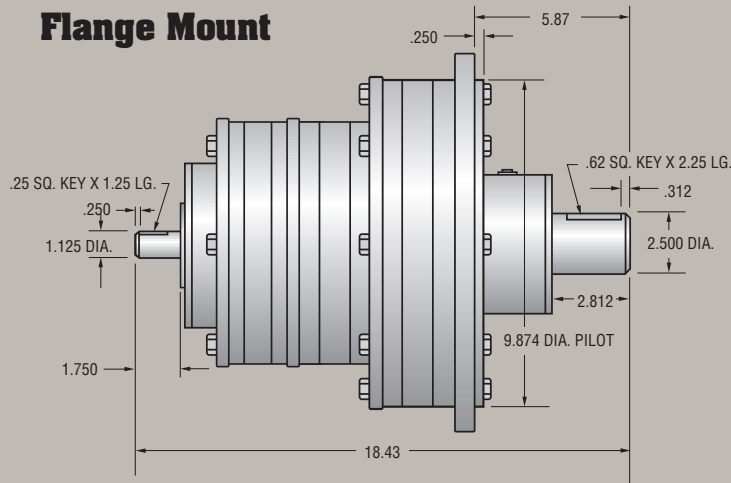

### Foot Mount

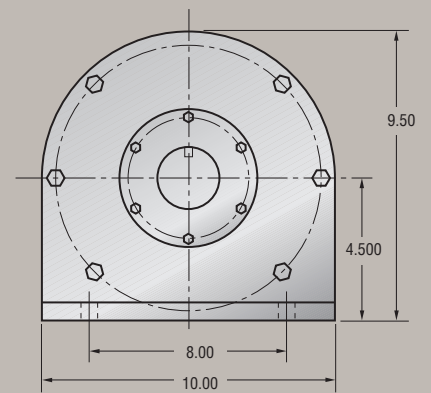
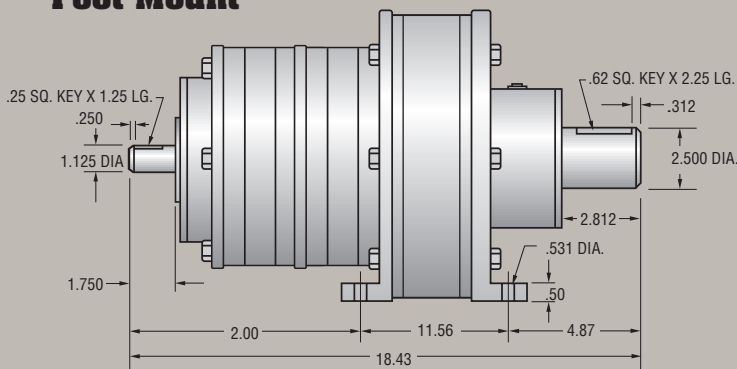

### Flange or Foot Mount w/SAE or NEMA Input

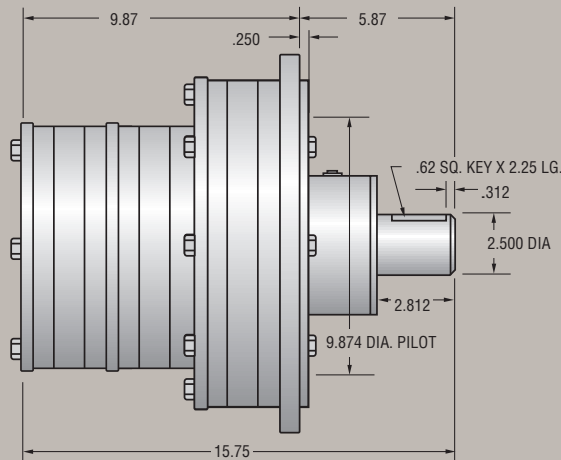

#### NEMA Electric Motor Direct Mount

"C" face direct couple of motor to speed reducer. No need for coupling or special motor mounts.

#### SAE Hydraulic Motor Direct Mount

2 bolt or 4 bolt direct couple of hydraulic motor to speed reducer. No need for coupling or special motor mounts.



*Byrne*  
**Gear Corporation  
of America**

- Planetary speed reducers
- High-speed increasers
- Custom design geared products

*"The Problem Solver"*

# Model 75-75-75S

## Triple Reduction Planetary Gear Reducer

Planetary Assembly	Ratios	OUTPUT HORSE POWER RATINGS (Adjusted for Thermal Efficiencies)						
		INPUT R.P.M.						
		100	580	720	870	1170	1430	1750
EEE	27.00	.99	3.38	3.93	4.49	5.52	6.35	7.32
EEA	31.50	1.25	4.26	4.96	5.66	6.97	8.02	9.24
EEB	36.00	1.67	7.31	8.50	9.70	11.94	13.74	15.83
EAA	36.75	1.12	3.83	4.45	5.08	6.26	7.20	8.29
CEE	39.00	.76	2.61	3.04	3.47	4.27	4.91	5.66
BEA	42.00	1.02	3.49	4.06	4.63	5.70	6.56	7.55
AAA	42.87	1.00	3.44	4.00	4.56	5.62	6.46	7.44
ECA	45.50	.96	3.30	3.83	4.38	5.39	6.20	7.14
EBB	48.00	1.26	5.97	6.95	7.93	9.76	11.24	12.94
AAB	49.00	1.23	5.89	6.85	7.82	9.62	11.07	12.76
ECB	52.00	1.16	5.65	6.57	7.50	9.23	10.62	12.24
CAA	53.08	.86	2.96	3.44	3.93	4.84	5.57	6.41
DEE	54.00	.61	2.08	2.42	2.76	3.40	3.91	4.51
BBA	56.00	.83	2.85	3.32	3.79	4.66	5.36	6.17
CCE	56.33	.59	2.02	2.35	2.68	3.30	3.80	4.37
CBA	60.67	.79	2.70	3.14	3.58	4.40	5.07	5.84
DEA	63.00	.77	2.62	3.05	3.49	4.29	4.94	5.69
BBB	64.00	.95	4.88	5.68	6.49	7.98	9.19	10.58
CCA	65.72	.74	2.55	2.96	3.38	4.16	4.79	5.52
CBB	69.33	.87	4.62	5.37	6.13	7.55	8.69	10.00
DEB	72.00	.84	4.50	5.23	5.97	7.35	8.46	9.74
DAA	73.50	.69	2.36	2.74	3.13	3.85	4.43	5.10
CCB	75.11	.81	4.37	5.08	5.80	7.14	8.21	9.46
DCE	78.00	.47	1.61	1.87	2.14	2.63	3.02	3.48
CCC	81.37	.51	2.89	3.56	4.07	5.01	5.76	6.64
DBA	84.00	.63	2.15	2.50	2.85	3.51	4.04	4.65
DCA	91.00	.59	2.03	2.36	2.70	3.32	3.82	4.40
DBB	96.00	.63	3.61	4.28	4.88	6.01	6.92	7.97
DCB	104.00	.58	3.34	4.05	4.62	5.68	6.54	7.53
DDE	108.00	.37	1.28	1.49	1.70	2.09	2.41	2.77
DCC	112.66	.36	2.10	2.60	3.13	3.99	4.59	5.28
DDA	126.00	.47	1.62	1.88	2.15	2.64	3.04	3.50
DDB	144.00	.42	2.42	2.99	3.61	4.52	5.21	6.00
DDC	156.00	.26	1.52	1.88	2.27	3.04	3.65	4.21
DDD	216.00	.23	1.30	1.60	1.97	2.43	2.80	3.22

Ratings based upon uniform steady and moderate shock loading. See load factor chart for details.

OUTPUT SHAFT RADIAL (overhung) LOAD CAPACITIES (at output r.p.m.)								
R.P.M.	10	20	30	50	100	200	300	500
Radial Capacity (lbs.)	8,200	6,660	5,800	5,000	4,100	3,900	3,250	2,600

OUTPUT SHAFT THRUST LOAD CAPACITIES (at output r.p.m.)								
R.P.M.	10	20	30	50	100	200	300	500
Radial Capacity (lbs.)	12,609	10,097	9,071	7,781	6,322	5,136	4,547	3,900

**OUTPUT SHAFT MAXIMUM CONTINUOUS TORQUE CAPACITY:** 18,753 lb./inches  
**OUTPUT SHAFT INTERMITTENT TORQUE CAPACITY:** 21,300 lb./inches  
**WEIGHT:** 160 lbs.  
**RATING SYSTEM:** All Ratings Based Upon American Gear Manufacturers' Association Standards



*Byrne*

*"The Problem Solver"*

Part of The Byrne Group

Copyright © Byrne Gear Corporation of America  
 Printed in U.S.A. 697

**GEAR CORPORATION OF AMERICA**

301 Byrne Gear Drive  
 P. O. Box 1789  
 Mansfield, Ohio 44901  
 Telephone: (419) 522-GEAR(4327)  
 Fax: (419) 525-2386  
 E-mail: byrne@byrnegroup.com  
 Visit our web site at: www.byrnegroup.com